



Nat. Corp. Uherské Hradiště

member of

*Aero*

Trust of Czechoslovak Aeronautical Works Prague

Czechoslovakia

# MANDATORY BULLETIN No. E 23/009a

Sheet. 1.....

of.....5.....

Effectivity: Gliders L23 Super Blaník prod. num. 897501 to 917930

Reason: Wheel spur adjustment

Realized on base of: Wheel spur break-down in operation

Description: Spur rod is replaced with two side plates with elastic elements according to following text in bulletin. In serial production it is introduced by a change nr. ZKA 70144 beginning with production number 918001.

To be accomplished not later than: Immediately after take over the bulletin.

To be accomplished by: Operator.

Cost covered by: Material by the producer joint-stock company  
LET Kunovice, CSFR

Material availability: Producer LET Kunovice, CSFR

Validity: January, the 1, 1992

Skrášek

.....  
Manufacturer

Rybka

.....  
Customer's Representative

Příhoda

.....  
State Aviation Inspection

Sovák

.....  
Ministry of Foreign Trade



H. Record into air-frame book of records after the bulletin realization

L 23/  
Spur rod exchange realization.

Date: .....

Realized by: .....

/Readable sign/

I. Accompanying documentation

Without influence.

---

L23/009a

Drawn up by:

Mitáš

Sheet:

Of: <sup>3</sup>5

---

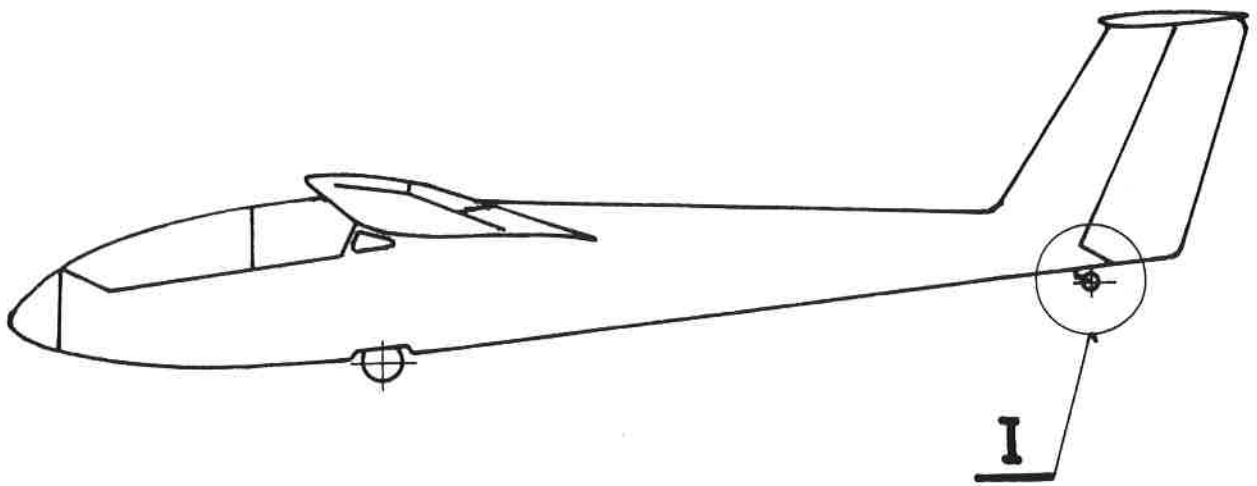

I

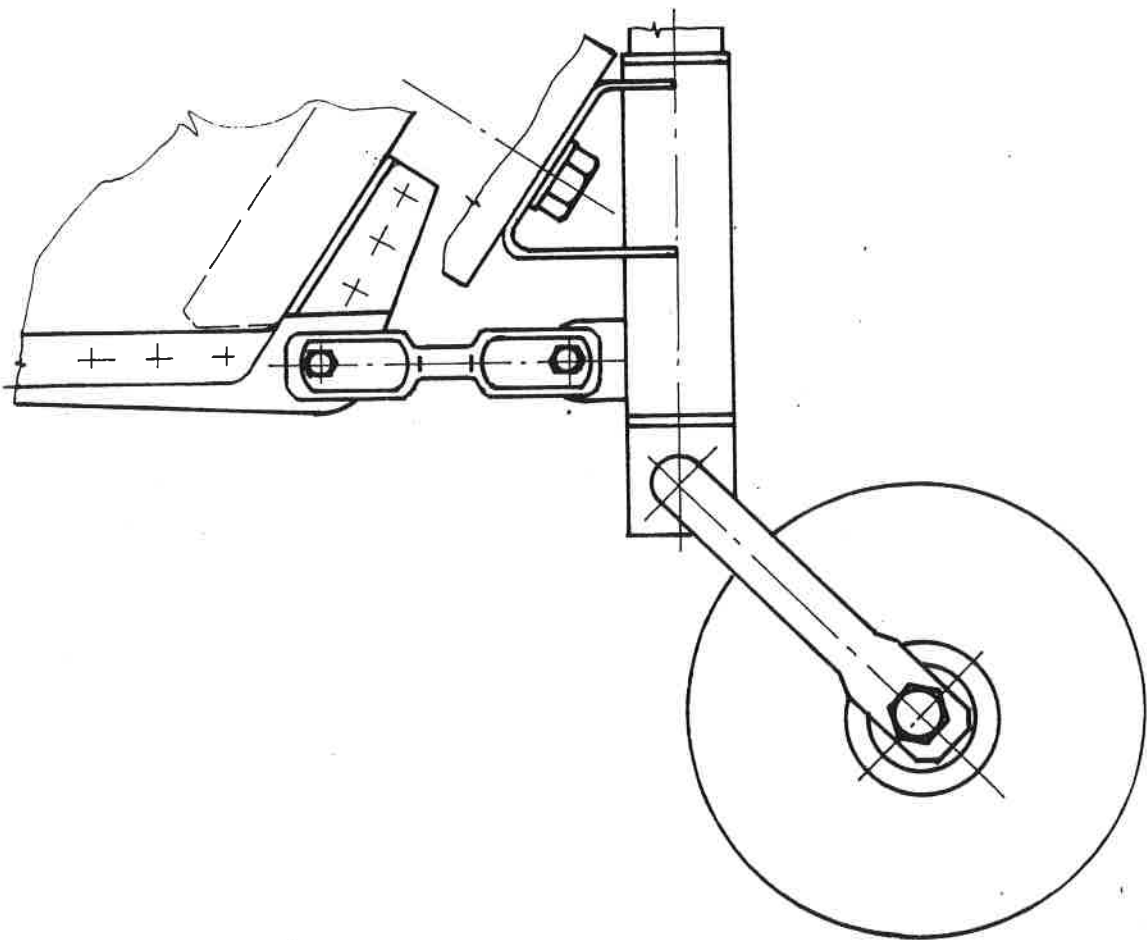

1

L23/009a	Vypracoval Mitaš	Kontroloval	Schválil <i>[Signature]</i>	List: 4 Listů: 5
----------	---------------------	-------------	--------------------------------	---------------------

I

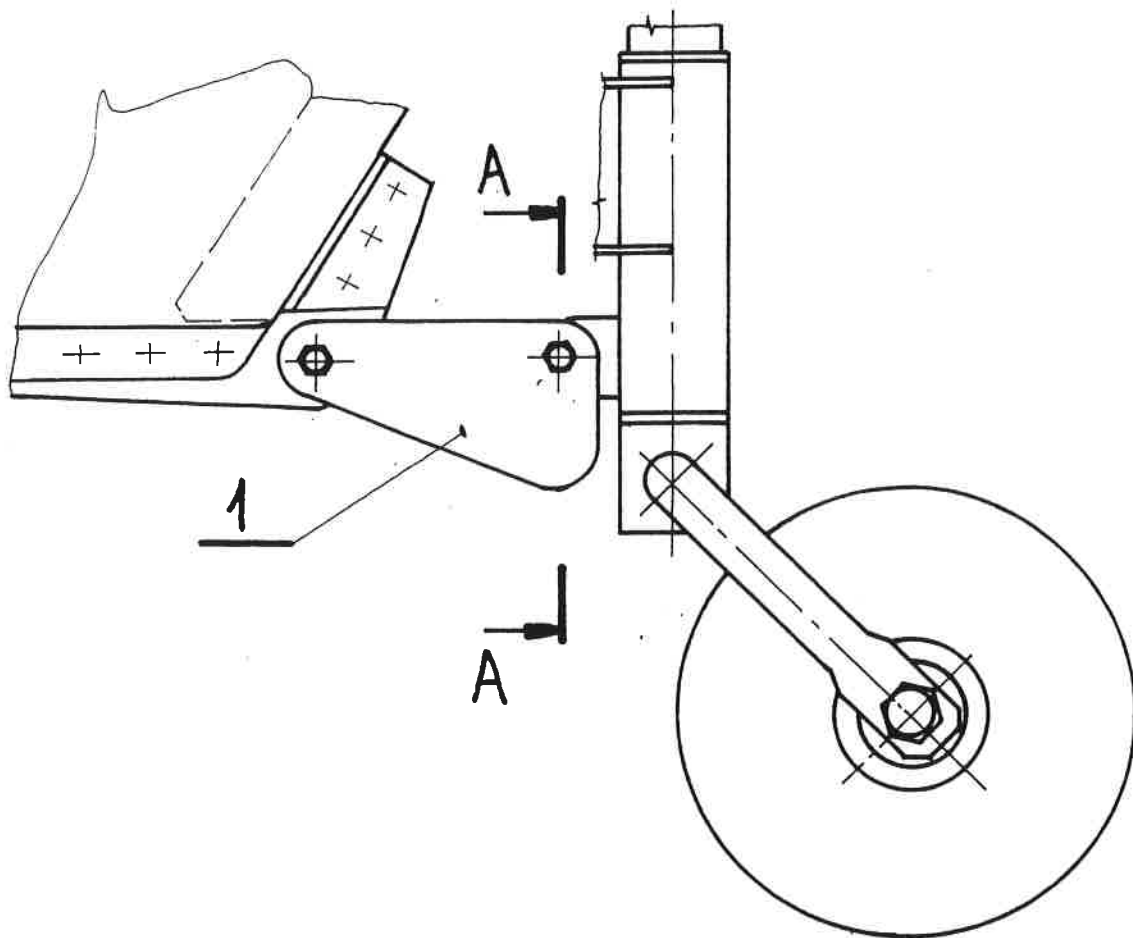

A-A

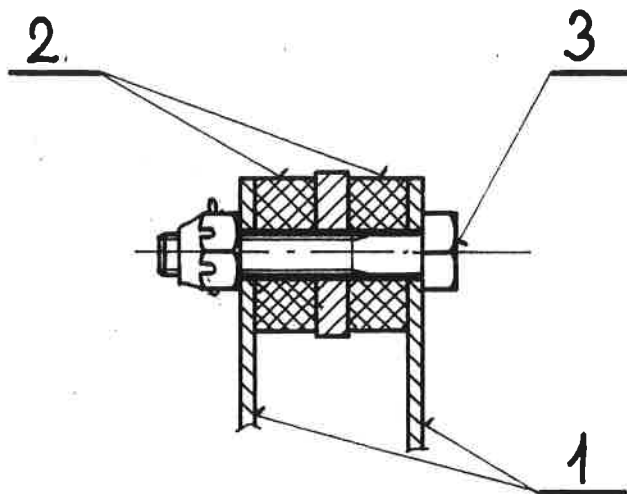

2

L23/009a	Vypracoval Mitaš	Kontroloval	Schválil 	List: 5 Listů: 5
----------	---------------------	-------------	--	---------------------