

SERVICE BULLETIN No. L 13/010

Sheet 1 of 4

Subject: L 13 Blanik sailplane Technical Manual

Reason: Contamination of the turn-and-bank indicator commutator in service caused by carbon dust.

Description: Amend the sailplane Technical Manual in accordance with this Bulletin. If a sailplane equipped with the LUN 1211.1 turn-and-bank indicator P/N 61..... has logged more than 50 flying hours clean its commutator as per instructions of this Bulletin.

Compliance: The bulletin to be incorporated immediately. Incorporation of the bulletin is responsibility of Operator.

Material-Costs and

Availability: Not applicable.

List of material and accomplishment instructions on 2 sheets form part of this Bulletin.

Enclosures: 2 sheets of illustrations.

Bulletin is effective from:

Manufacturer's
Representative
Ing. Černocký

Foreign Trade
Corporation-Omnipol
Pavlovský

Customer's
Representative
Ing. Boron

State Aviation
Inspection
Kadleček

BLANIK Technical Manual, Part II. Operating Instructions, Chapter I. Aircraft Servicing, paragraph 2.a. Inspections after 50 flying hours - equipment is to be ammended as follows:

" Sailplanes fitted with the turn-and-bank indicator, Model LUN 1211.1 P/N 61... and higher shall have cleaned the indicator commutator from carbon dust.

For this purpose are all the instruments furnished with a plastic sack, containing tweezers, polishing paper, wooden stick and a hair brush.

The following equipment is further needed to clean the commutator:

1. Screwdriver for watch repairs
2. A rubber ball or air pump for blowing-through (ensuring clean air supply)
3. Cement C 5001/110 or other varnish for locking grub screws.

Accomplishment Instructions:

1. Removal of casing to Fig. a.

Release the locking grub screw dia. 3.5 item (1) using a screwdriver. Remove the lock nut item (2) and instrument casing item (3).

2. Cleaning of commutator from carbon dust to Fig. b, c.

Cut the polishing paper to 8mmx12 mm size. Form the polishing paper so that its shape correspond to Fig. b. Grip the polishing paper into tweezers and roughly clean the carbon dust from commutator item (4) while revolving the flywheel item (5) by hand. Clean the commutator separation slots using a wooden stick and a hair brush. Connect the instrument to a source of direct current of 4 V. Sense of flywheel rotation must be clockwise when viewing upon the regulator side. Grip the polishing paper into tweezers and polish the commutators surface during the instrument in operation. Disconnect the instrument from power supply, clean it by hair brush and remove any contamination by blowing-through using a rubber ball or a suitable air pump. It is recommended not to disassemble the spring item (6) when polishing and cleaning the commutator.

3. Assembly to Fig. a

Install the casing item (3) on the instrument, attach the lock nut item (2) and secure by grub screw dia. 3.5 mm - item (1).

The grub screw dia. 3.5mm to be secured by the C 5001/1100 cement.

NOTE: Removal of securing cement from the grub screw (item 1) after 50 flying hours has no effect upon the warranty of instrument which is further valid."

Symbols to illustrations:

- a., b., c., = Figure designation
1, 2, etc. = Item designation
P
P
P
P
P

a

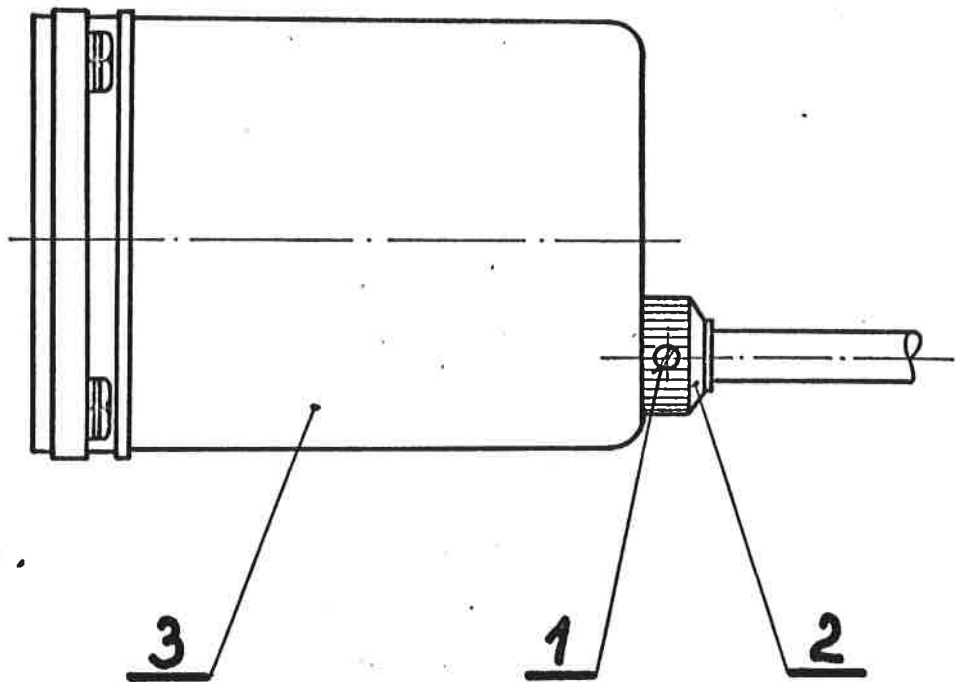

b

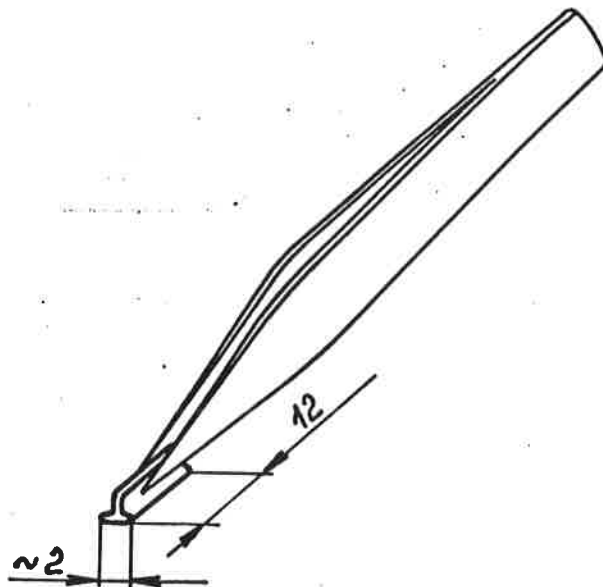

RB.L 13/010

Vypracoval:
Šupka

Kontroloval:

Schválil:

List:

3

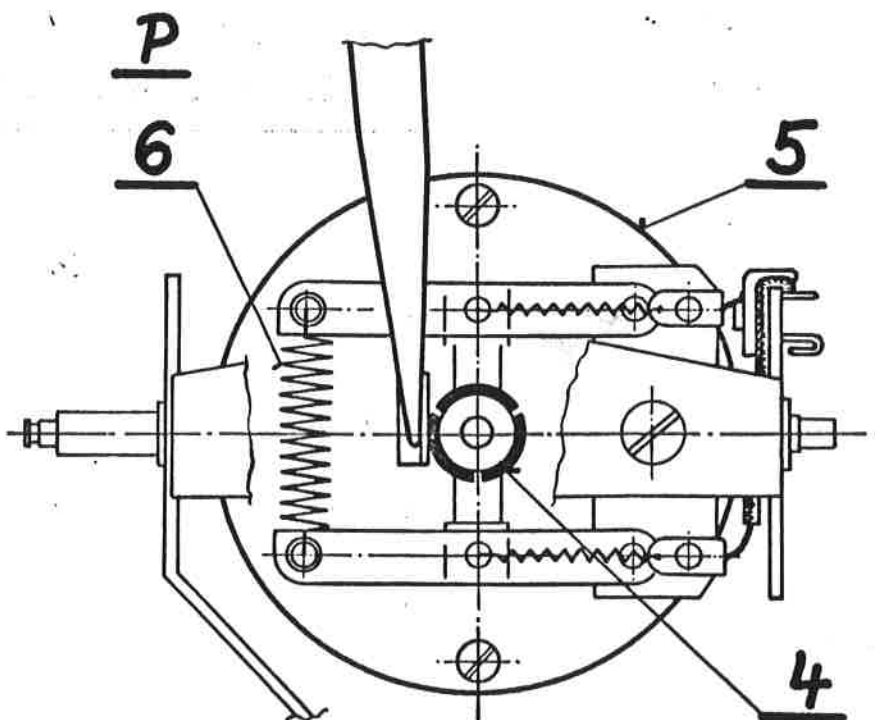
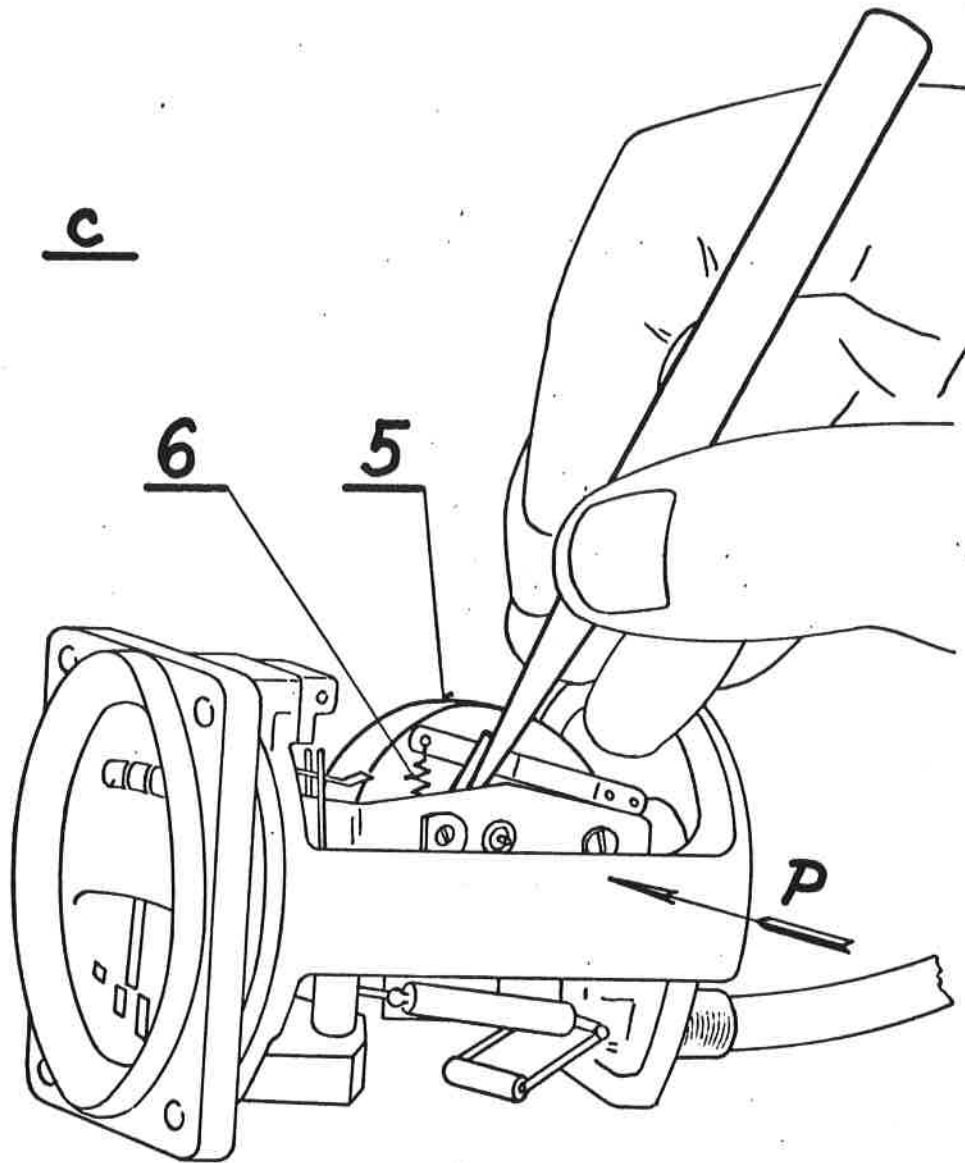

23.113/010	Vypracoval: Šupka	Kontroloval: <i>[Signature]</i>	Schválil: <i>[Signature]</i>	List: 4
------------	----------------------	------------------------------------	---------------------------------	---------