



Comp. Limited Kunovice

*Aero*

Company Limited Prague Czech

# MANDATORY BULLETIN No. L 23/013a

Sheet: 1  
Of: 8

**Effectivity:** L 23 Super Blaník sailplanes of the following S/Nos.:  
917803, 917814, 917815, 917817, 917826, 917905, 917906, 917911,  
917912, 917914, 917915, 917916, 917917, 917921, 917922, 917923,  
917924, 917926, 917927, 917928, 928001, 928002, 928006, 928007.

**Reason:** Compliance of sailplanes delivered to the U.S.A. with the  
FAA requirements.

**Description:** Placards are additionally installed in both pilot's cockpits  
and a luggage net in the luggage hold. In production introduced  
by the change No. ZKA 70168 starting from the S/N 928008.

**To be accomplished not later than:** After receipt of the Bulletin and material.

**To be accomplished by:** Operator.

**Cost covered by:** The Producer LET com. limited Kunovice - material.  
The Operator - labour.

**Material availability:** LET com. limited Kunovice.

**Validity:** at the day of the Bulletin receipt.

**Manhours:** 5 manhours.

..... Skrášek .....

Manufacturer



*[Signature]*

Příhoda March 17, 1993

.....  
Civil Aviation Inspectorate

A. Work procedure

1. Cut off the heads of the four (4) rivets fastening the original placard (pos. 1, fig. 1, det."A") on the fore instrument board. Remove the placard. Clean the rest of the rivets to be flush with the instrument board. Put on place the placard pos. 2 instead of the original one, drill it through with the instrument board and fasten with rivets pos. 10. Drill through and fasten with rivets the placards pos. 3, 4 one after the other.
2. In accordance with fig. 1, det."B" (the right trimming in the fore cockpit) remove the seal and wire (pos. 11,12) from the lever of canopy emergency jettisoning: WARNING! DON'T TURN THE LEVER!  
Remove the screws and washers pos. 15,16 on the whole periphery of the trimming. Remove the trimming.  
Remove the original placard pos. 5.  
Put on the place the placards pos. 6,7,8 drill them through with the trimming and fasten with rivets pos. 13 with washers pos. 14 under the closing heads of the rivets one after the other.  
Put the trimming back on place and fasten it with the original screws and washers, seal the lever of the emergency jettisoning using a new seal and wire.
3. Cut off the heads of the four (4) rivets fastening the original placard (see fig. 2, det. "C") on the aft instrument board. Remove the placard. Clean the rest of the rivets to be flush with the instrument board. Put on place the placard pos. 2 instead of the original one, drill it through with the instrument board and fasten with rivets pos. 10. Drill through and fasten with rivets the placards pos. 3,4 on the right side of the instrument board (see fig. 1, det. "D") one after the other.
4. In accordance with fig. 2, det. "E" (trimming on the RH side in the aft cockpit) - Use the same procedure as in the fore cockpit (see item 2).
5. In accordance with fig. 3, det. "F" - Remove the placard pos. 5 on the frame No. 5 after the rest of the aft pilot, replace it with a new one of the same pos. No. and fasten with rivets pos. 10.
6. In accordance with fig. 4, det. "K", view "P" - Drill 4 holes of 5,3 diameter. Fasten the top and bottom luggage net pos. 15, 16

L 23/13a

using the screws and nuts pos. 15, 16 and washers pos. 17, 18, 19. The bottom suspensions of the nut should be fastened to the riveted nuts in the floor, using the screws pos. 17 and shim washers pos. 20.

B. Material necessary for the modification of one Sailplane

Pos.	Unit of measure	No. of pcs.	Description	Dwg.No./nomenclature	Note
2	pcs	2	Placard	A 780 352 N	
3	pcs	2	Placard	A 780 353 N	
4	pcs	2	Placard	A 780 354 N	
6	pcs	2	Placard	A 780 355 N	
7	pcs	2	Placard	A 780 356 N	
8	pcs	2	Placard	A 780 357 N	
9	pcs	1	Placard	A 780 358 N	
10	pcs	24	Rivet	B 082 472 N b.v.	
11	pcs	2	Seal	8719 4008	
12	kgs	0,001	Wire	2081 1905	
13	pcs	26	Rivet	B 082 473 N b.v	
14	pcs	26	Washer	3555 1001	
15	pcs	1	Luggage net, top	A 770 421 N	
16	pcs	1	Luggage net, bottom	A 770 422 N	
17	pcs	6	Screw	3185 0514	
18	pcs	4	Nut	3372 0005	
19	pcs	4	Washer	3555 1005	
20	pcs	2	Shim washer	3561 2510	

C. Illustrations

- Fig. 1 - Detail views in the fore cockpit.
- Fig. 2 - Detail view in the aft cockpit.
- Fig. 3 - Detail view on the frame No. 5.
- Fig. 4 - Details of fastening the luggage net.

D. Supplementary documents necessary for the bulletin

Without any addition additional documentation.

E. Necessary tool

The operator will use own tools.

L 23/013a

F. Spare parts during operation

Without influence.

G. Glider mass

+ 1. (one) lb

H. Record into the airplane log book after issue of the Bulletin

L 23/013a

"The placards were additionally installed in both cockpits and a luggage net in the luggage hold in accordance with FAA requirements."

Date: ..... Accomplished by: .....  
(legible signature)

I. Accompanying Documentation

New Flight Manual No. Do-L23.1011.5.

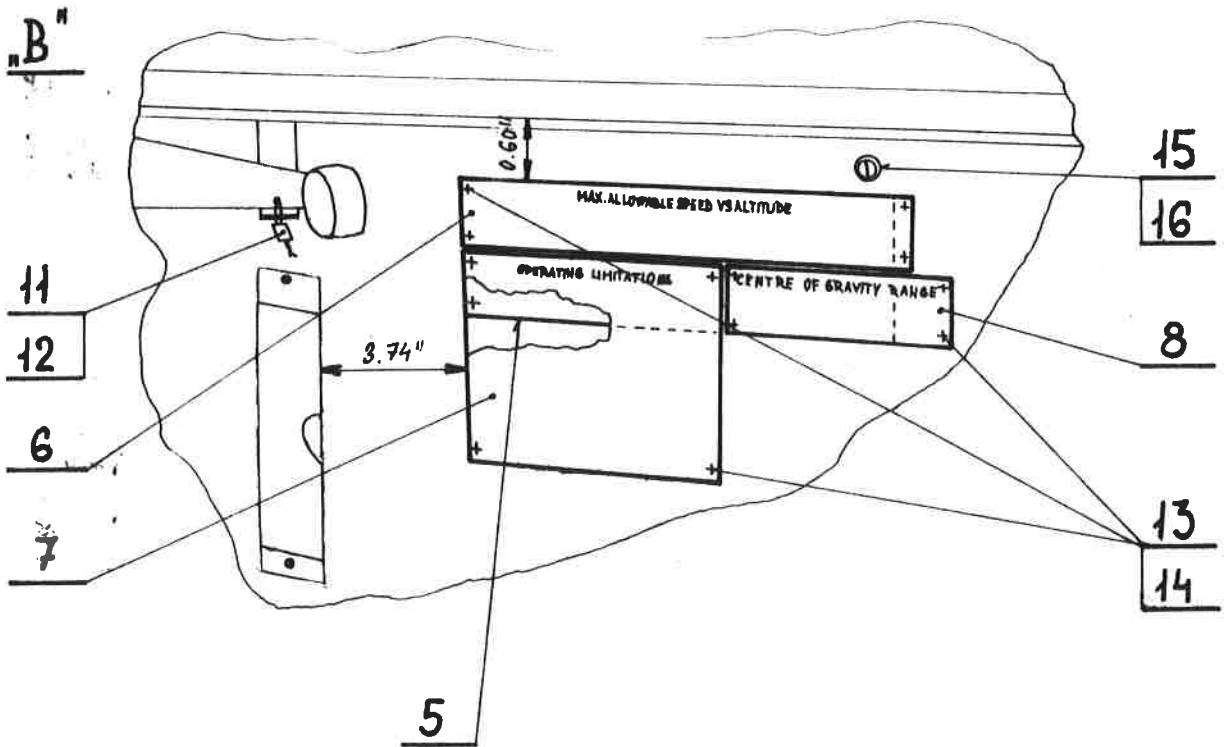
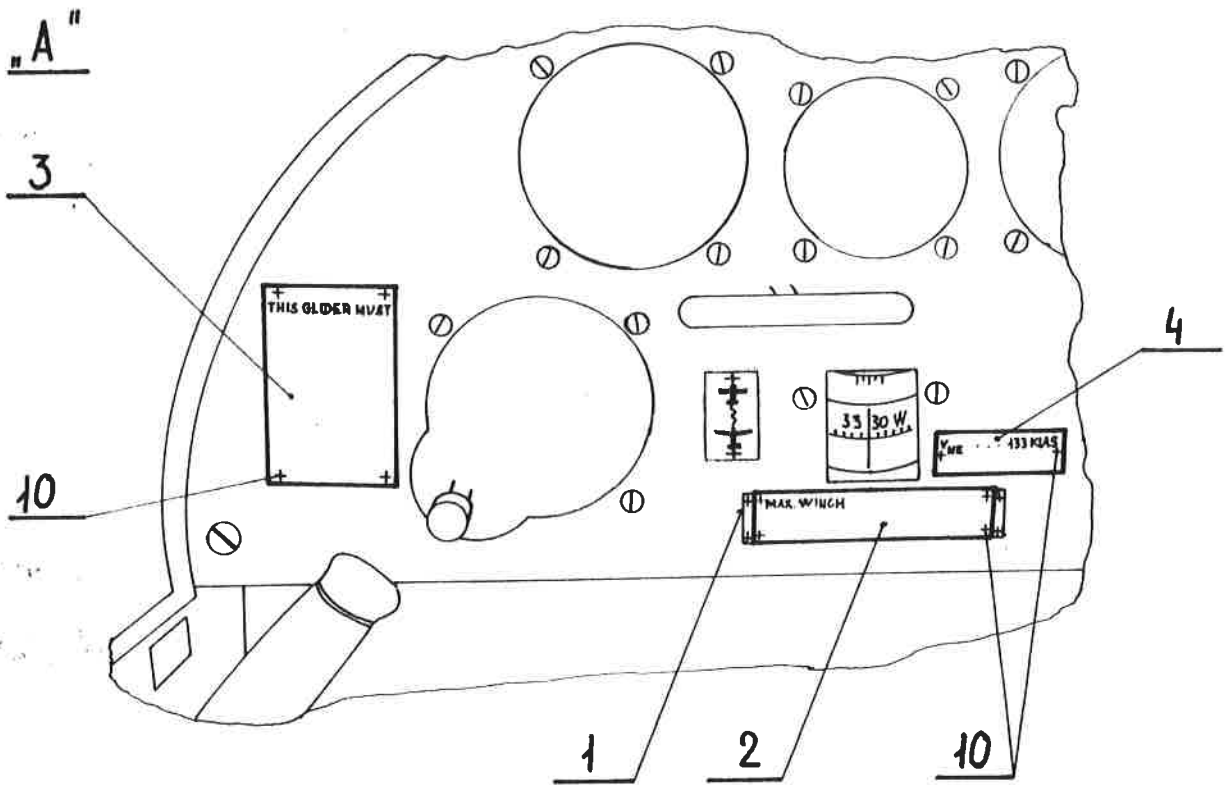

1

123/013 a	Vypracoval . Kufina	Kontroloval <i>[Signature]</i>	Schválil <i>[Signature]</i>	List: 5
				Listo: 6

C''

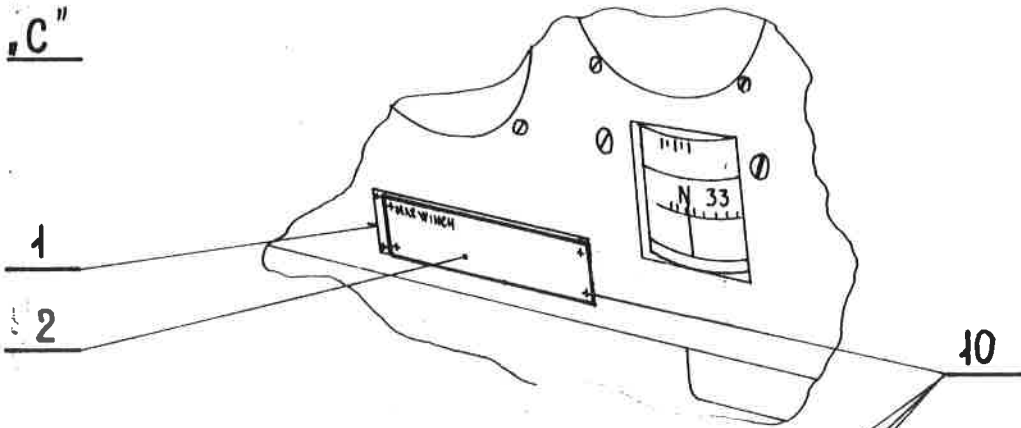

D''

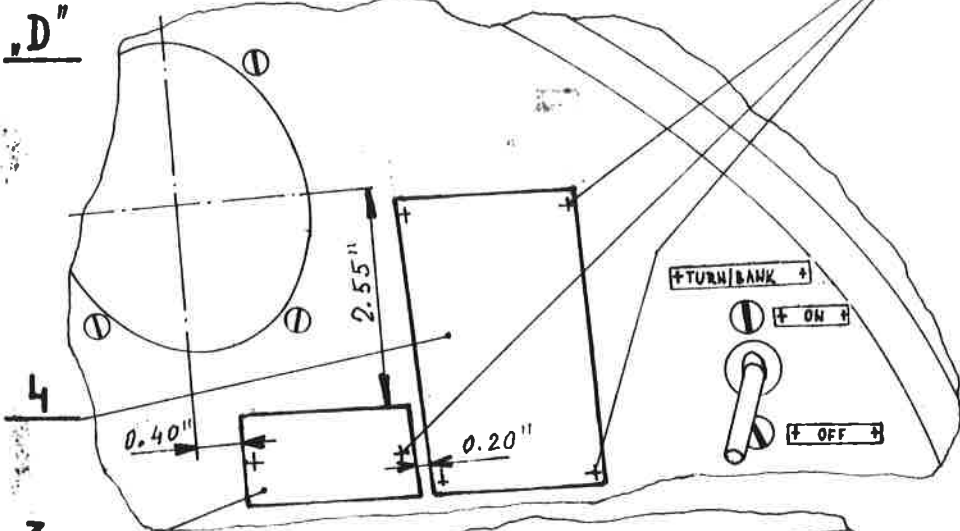

E'

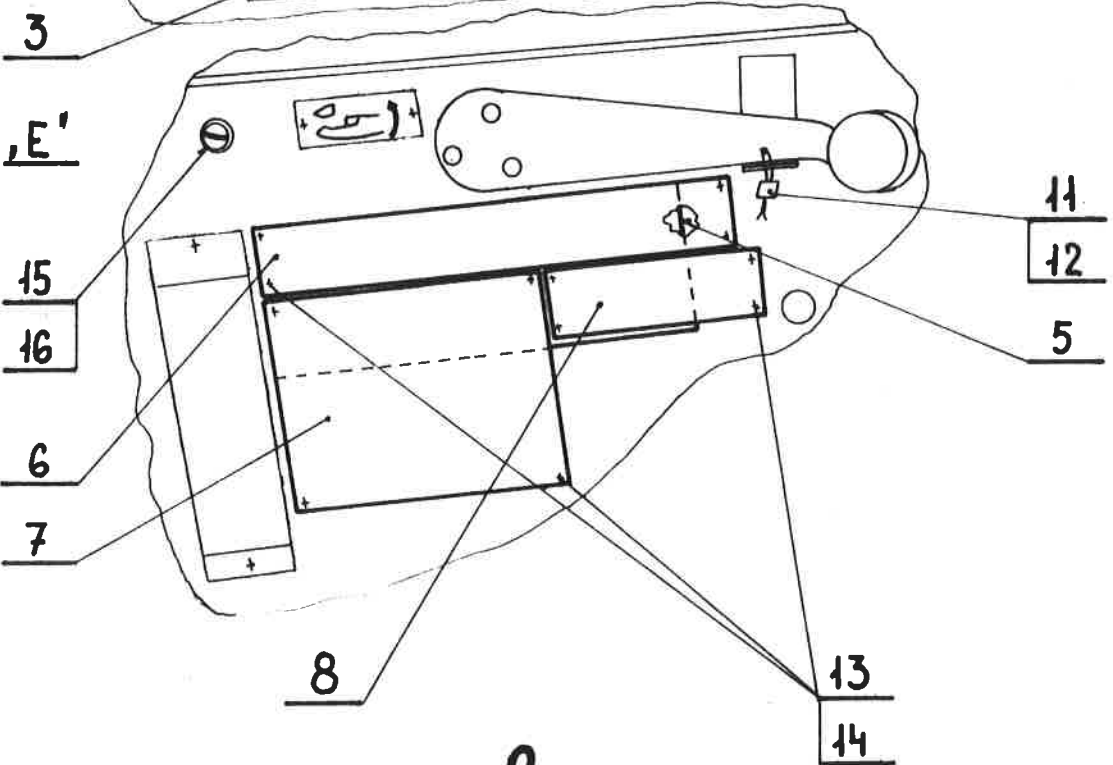

2

L23/013 a	Vypracoval Kučina	Kontroloval <i>[Signature]</i>	Schválil <i>[Signature]</i>	List: 6 Listo: 8
-----------	----------------------	-----------------------------------	--------------------------------	---------------------

F''

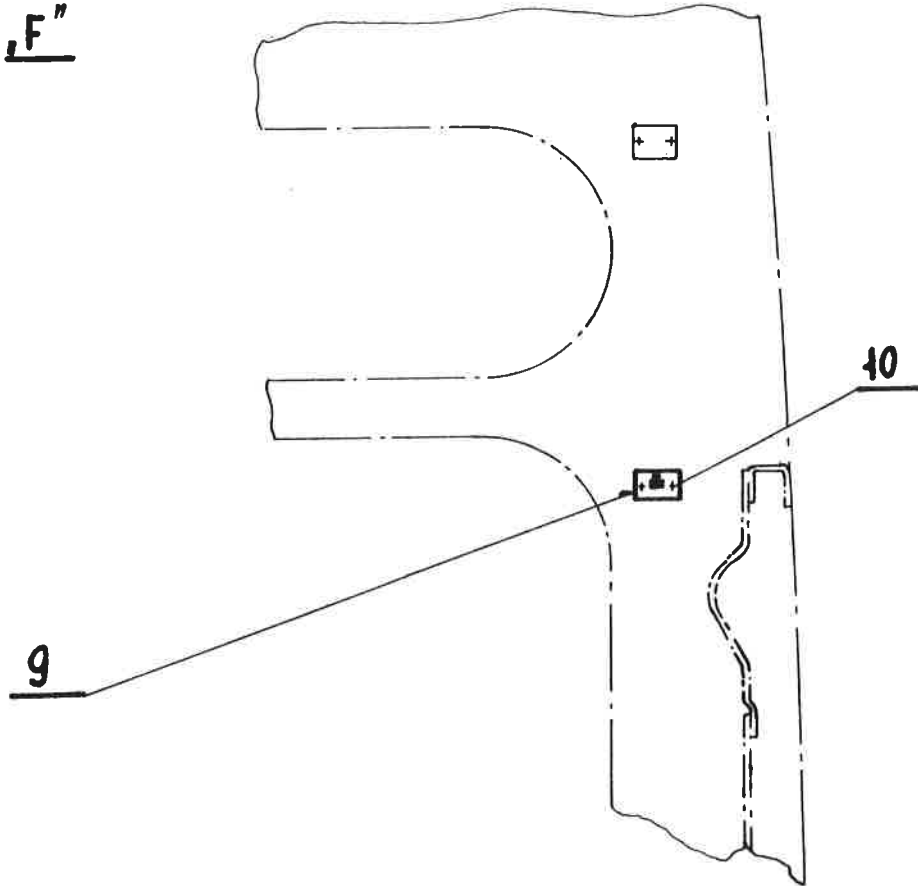

3

128/013a	Vypracoval Kutina	Kontroloval <i>[Signature]</i>	Schválil <i>[Signature]</i>	List: 7 Listo: 8
----------	----------------------	-----------------------------------	--------------------------------	---------------------

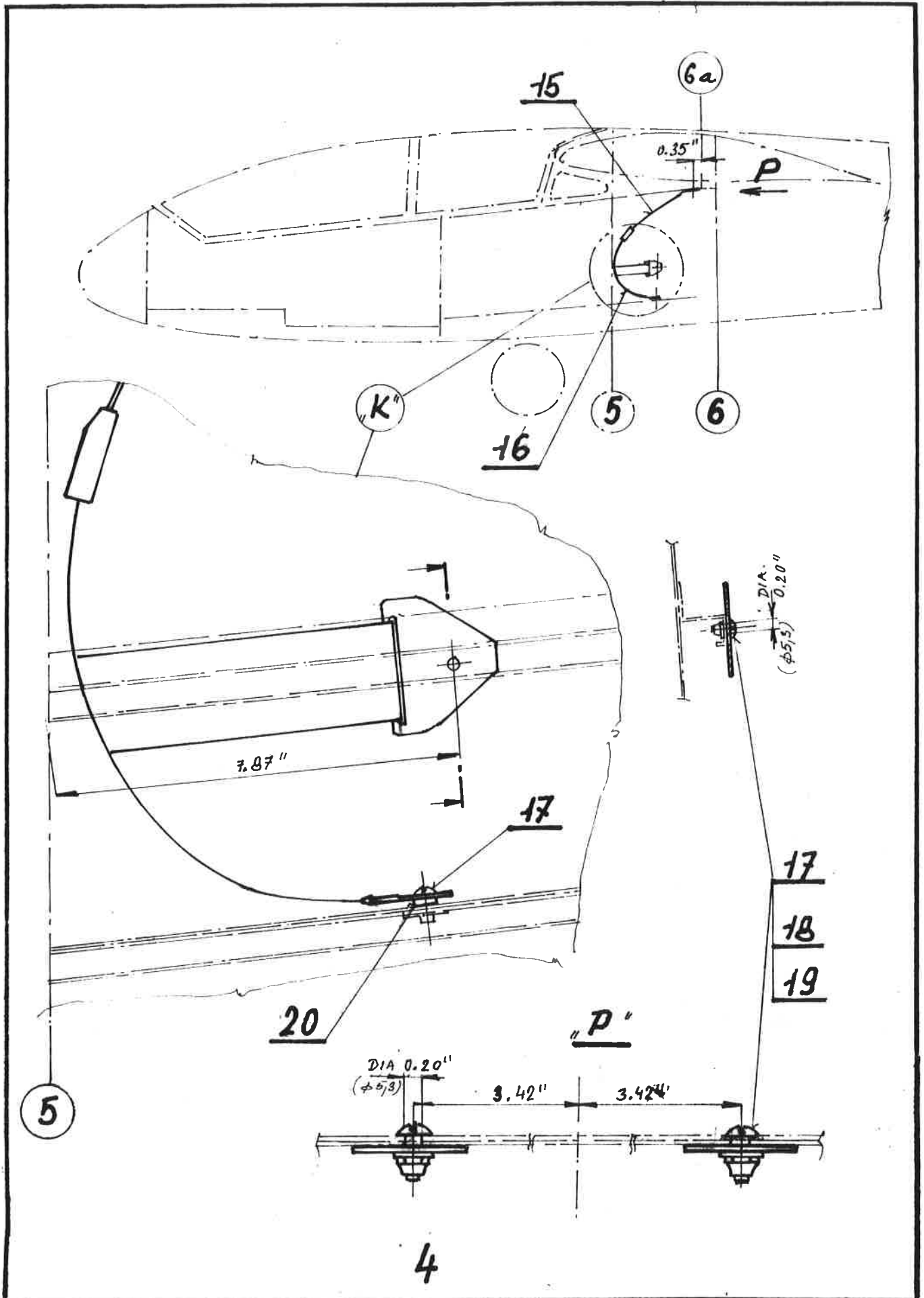

L23/013 a	Vypracoval Hošička	Kontroloval <i>[Signature]</i>	Schválil <i>[Signature]</i>	List: 8 Listo: 8.
-----------	-----------------------	-----------------------------------	--------------------------------	----------------------