



Aeronautical Works, Kunovice, Czech Republic

Cero

Holding Company, Prague, Czech Republic

MANDATORY BULLETIN No. L23/026a

Sheet: 1
Of: 1
Enclosures: See Descr.

Effectivity: Flight Manual for the L23 SUPER BLANIĀK
(Do-L23.1012 and other language versions)

Reason: Flight Manual supplementation and minor changes

Description: Flight Manual holders:
cancel following pages:

- Do-L23-1012.1: 0-1,0-3,7-1
- Do-L23.1012.3: 0-1,0-3,7-1
- Do-L23-1012.4: 0-1,0-2,7-1
- Do-L23.1012.5: 0-1,0-3,2-5,2-10,2-11,
6-5,6-6,6-7,7-1
- Do-L23.1012.6: 0-1,0-3,7-1

insert into Flight Manual following pages,
dated Dec 20/95

- 0-1,0-3,7-1,7-4,7-5
- 0-1,0-3,7-1,7-4,7-5
- 0-1,0-2,7-1,7-3,7-4
- 0-1,0-3,2-5,2-10,2-11,6-5,6-6,6-7,7-1
7-4,7-5
- 0-1,0-3,7-1,7-4,7-5

To be accomplished not later than: Immediately after receiving this Bulletin

To be accomplished by: Flight Manual holder

Cost covered by: No cost arise

Material availability: New and revised pages are enclosed

Validity: Since the date of receiving

Manhours: -

Manufacturer

96-01-26



Civil Aviation Inspectorate



0.1. RECORD OF REVISIONS

Any revision or amendment of the present Manual will be issued in the form of Bulletins, approved by the Civil Aviation Inspectorate of the Czech Republic, supplement of which will contain new (revised) pages. User's duty is to make a note about revisions in the Record of revisions and to replace existing pages with revised and effective ones. Revised or amended parts of the text will be indicated by a vertical line in the left hand margin and the revision No. and the date will be shown on the bottom left hand of the page.

The original issue of this Brazilian Sailplane Flight Manual includes Revision No 2 of the approved Flight Manual in English.

Rev. No.	Affected Section	Affected pages	Date	Bulletin No.	Date of Bulletin approval	Date inserted and signature
1.	0, 7	0-1, 0-3, 7-1, 7-4, 7-5	20.12.1995	L23/026a		



0.2. LIST OF EFFECTIVE PAGES

Section	Page	Date	Section	Page	Date	
0	1	Dec 20/95	4	Appr. 19	Feb 24/95	
	2	Feb 24/95		Appr. 20	Feb 24/95	
	3	Dec 20/95		Appr. 21	Feb 24/95	
	4	Feb 24/95		Appr. 22	Feb 24/95	
1	1	Feb 24/95	5	Appr. 23	Feb 24/95	
		Feb 24/95		Appr. 1	Feb 24/95	
		Feb 24/95		Appr. 2	Feb 24/95	
		Feb 24/95		Appr. 3	Feb 24/95	
2	4	Feb 24/95	6	4	Feb 24/95	
		Appr. 1		1	Feb 24/95	
		Appr. 2		2	Feb 24/95	
		Appr. 3		3	Feb 24/95	
		Appr. 4		4	Feb 24/95	
		Appr. 5		5	Feb 24/95	
		Appr. 6		6	Feb 24/95	
		Appr. 7		7	Feb 24/95	
		Appr. 8		8	Feb 24/95	
		Appr. 9		9	Feb 24/95	
3	Appr. 10	Feb 24/95	7	1	Dec 20/95	
		Feb 24/95		2	Feb 24/95	
		Feb 24/95		3	Feb 24/95	
		Feb 24/95		4	Dec 20/95	
		Feb 24/95		5	Dec 20/95	
4	Appr. 1	Feb 24/95	8	1	Feb 24/95	
		Feb 24/95			2	Feb 24/95
		Feb 24/95				Feb 24/95
		Feb 24/95				Feb 24/95
		Feb 24/95				Feb 24/95
		Feb 24/95				Feb 24/95
		Feb 24/95				Feb 24/95
		Feb 24/95				Feb 24/95
		Feb 24/95				Feb 24/95
		Feb 24/95				Feb 24/95
		Feb 24/95				Feb 24/95
		Feb 24/95				Feb 24/95
		Feb 24/95				Feb 24/95
		Feb 24/95				Feb 24/95
		Feb 24/95				Feb 24/95
		Feb 24/95				Feb 24/95
		Feb 24/95				Feb 24/95



SECTION 7

Sailplane and systems description

CONTENTS

- 7.1 Introduction
- 7.2 Sailplane description
- 7.3 Front seat ballast
- 7.4 Front cockpit
- 7.5 Rear cockpit

7.4 FRONT COCKPIT

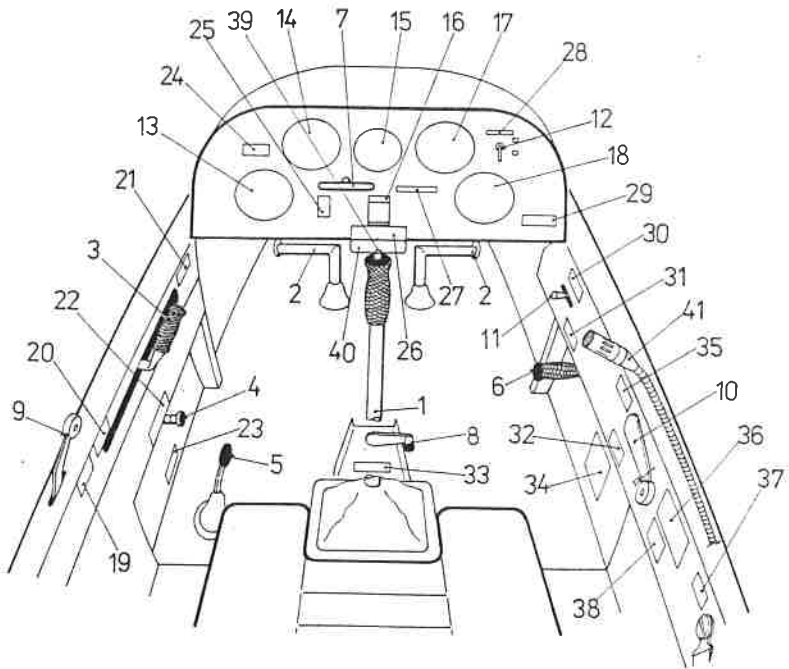

Fig. 7-2

(1)Control column, (2)Rudder pedals, (3)Airbrake handle, (4)Elevator trim handle, (5)Wheel brake handle, (6)Landing gear handle, (7)Rope release mechanism, (8)Rudder pedals adjustment, (9)Front cockpit hood opening handle, (10)Handle for emergency release of the front cockpit hood, (11)Ventilator fan switch, (12)Turn-and-bank indicator switch, (13)Altimeter, (14)Airspeed Indicator, (15)Turn-and-bank indicator, (16)Compass, (17) and (18)Vertical speed indicators, (19)Label "Front cockpit hood opening", (20)Label "Airbrakes extended", (21)Label "Airbrakes retracted", (22)Label "Elevator trim control", (23) Label "Wheel brake", (24)Label "No smoking", (25)Label "Tow release", (26)Label "Max. airspeeds", (27)Identification number, (28)Label "TURN-AND-BANK INDICATOR", (29)Label "Maneuvers with wing tip extensions forbidden", (30)Label "Ventilator fan", (31)Label "Landing gear extended", (32)Label "Landing gear retracted", (33)Label "Adjustment of pedals", (34)Label "Max. pilot weight", (35)Label "Front cockpit hood emergency release", (36)Label "Permitted maneuvers", (37)Label "Seat position", (38)Label "Center of gravity", (39)Radio control button, (40)Battery for turn-and-bank indicator

7.5 REAR COCKPIT

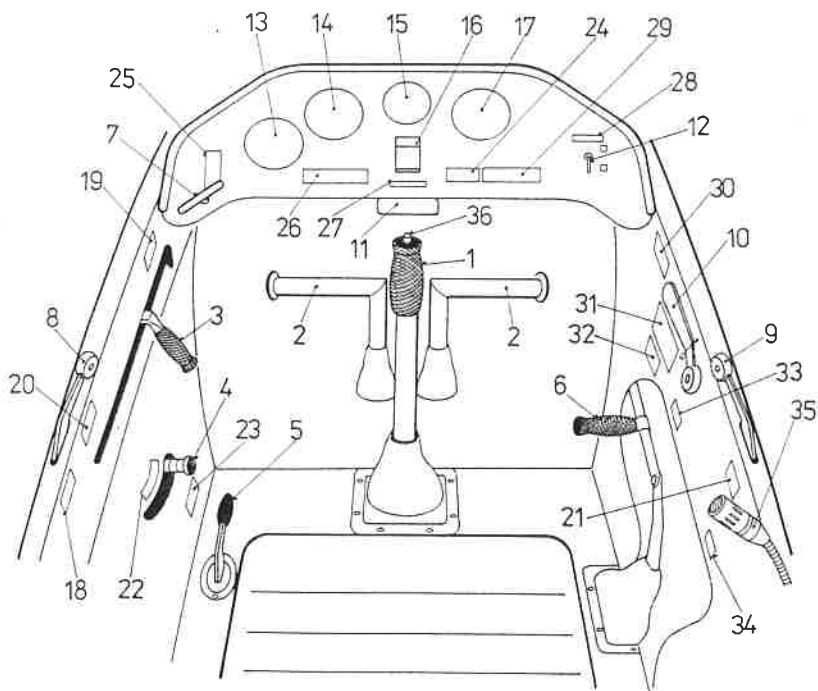

Fig. 7-3

(1)Control column, (2)Rudder pedals, (3)Airbrake handle, (4)Elevator trim handle, (5)Wheel brake handle, (6)Landing gear handle, (7)Rope release mechanism, (8) and (9)Rear cockpit hood opening handle, (10)Handle for emergency release of the front cockpit hood, (11)Battery for turn-and-bank indicator, (12)Turn-and-bank indicator switch, (13)Altimeter, (14)Airspeed indicator, (15)Turn-and-bank indicator, (16)Compass, (17)Vertical speed indicators, (18)Label "Airbrakes extended", (19)Label "Airbrakes retracted", (20) and (21)Label "Rear cockpit hood opening", (22)Label "Elevator trim control", (23)Label "Wheel brake", (24)Label "No smoking", (25)Label "Tow release", (26)Label "Max. airspeeds", (27)Identification number, (28)Label "TURN-AND-BANK INDICATOR", (29)Label "Maneuvers with wing tip extensions forbidden", (30)Label "Front cockpit hood emergency release", (31)Label "Permitted maneuvers", (32)Label "Center of gravity", (33)Label "Landing gear extended", (34)Label "Landing gear retracted", (35)Microphone, (36)Radio control button