

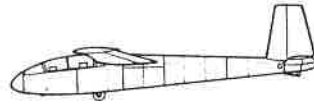

Aircraft Industries, a.s.



MANDATORY BULLETIN

MB No. : L13 / 105 a

Concerning: All L13 , L13A BLANÍK gliders

Reason: Check of the control bridge at the place of gripping of control levers in the front and rear cockpit to exclude presence of eventual cracks .

To be carried out not later than: At the nearest periodic maintenance of A - type , at latest till three months after receipt of bulletin .

To be carried out by: Operator or authorized service center

Costs covered by: Operator

Necessary material to be supplied by: Producer AIRCRAFT INDUSTRIES a.s.
686 04 Kunovice
the Czech Republic

Bulletin becomes effective : On the day of approval

Sheets : 3

A handwritten signature in black ink, appearing to read 'Pešák'.

Pešák Miroslav
Chief Designer

Technical content of this document has been approved based on the Design Organisation Approval No. EASA.21J.119
22. 5. 2007

A. WORK PROCEDURE

1. Dismantle the covers of both front and rear lever .
2. Inspect visually by means of 6x magnifying magnifier the bedding of front and rear control lever on the control bridge Dwg. No. A401 001N (old Dwg. No. L13.401-Z1) or Dwg. No. A740 370N, according to the specified design of sailplane, at the places around welds and bends (according to Fig.1 on both sides of the bridge) for presence of cracks .
Lighten up inspected places properly. For visually inspection deflect gradually the control lever to the right side endstop (minimum aileron deflection) and still press on the control lever handle to the right with moderate pressure 40 ± 10 N up to the endstop - inspect the relevant part of the bridge, at which springing it causes sharpening of eventual cracks. By the same method carry out inspection at left deflection of control lever. Crack incidence is not allowed .
Carry out checks at designated places of the control bridge at control levers in front and rear cockpit.
3. Inspection is to be carried out :
At the nearest periodic maintenance of A-type , at latest till three months after receipt of Bulletin .
Next inspections of the Control bridge for presence of cracks are to be carried out regularly at Periodic inspections type - A based on their prolongation according to the :
 - Documentation Bulletin No. L13 / 009d . . for L13 sailplane
 - Documentation Bulletin No. L13 / 010d . . for L13 sailplane - without overhauls
 - Documentation Bulletin No. L13 / 011d . . for L13A sailplane
4. In a case that bedding is in good order carry out record into the Sailplane logbook according to the point H and continue in operation according to the relevant operation conditions for specified sailplane.
5. In a case that some cracks in a bedding have been found, it is necessary to carry out replacement of defected control bridge for a new one according to the Dwg. No. A740 370 N design before continuing operation. For L13 glider there is also installation of original control bridge Dwg. No. A401 001N allowed, provided operator or servicing centre has original Bedding Dwg.No. A741 215N (old Dwg.No. L13.401-25.P1) as unused spare part at disposal.
Carry out replacement according to the Technical and Maintenance Manual of the L13 sailplane / Edition No.4 from the year 1978 or according to the Operational and Maintenance Manual of L13 sailplane - without overhauls or according to the Operational and Maintenance Manual of L13A sailplane, depending on which Manual is actual for given sailplane.
Inform immediately manufacturer about found defect at the same time with handover of sailplane operation data with a view to aerial acrobatics rate.
6. Reinstall the covers of control levers on the glider after performing the inspection.

B. MATERIAL REQUIRED FOR MODIFICATION OF ONE GLIDER

Beding Dwg.No. A740 371N - according to the result of inspection .

C. ILLUSTRATED PART

Fig. No. 1

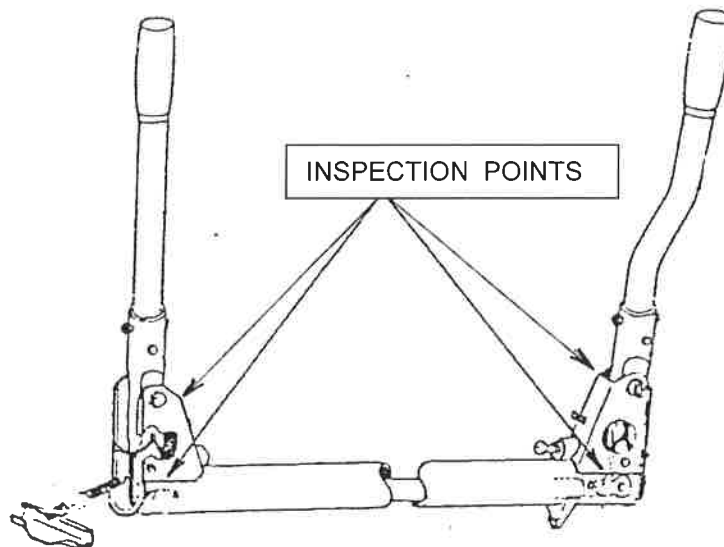

D. DOCUMENTATION REQUIRED

- Technical Manual of the L13 Sailplane - 4.issue or
 - Manual for Operation and Maintenance of the L13 Blanik Saiplane without overhaul or
 - Manual for Operation and Maintenance of the L13A Blanik Saiplane
- depending on which Manual is actual for given glider .

E. TOOLS REQUIRED

Magnifier 6x magnifying .

F. SPARE PARTS IN OPERATION

Not affected .

G. GLIDER MASS

Not affected .

